

Business Energy Efficiency Incentive Programs Pennsylvania Act 129 Met-Ed, Penelec and Penn Power



Linda Rasor, CEM & CEPP

Sr. Program Outreach Lead

SAIC[®]
From Science to Solutions

Program Incentives

q **Incentives to the following customer categories:**

- Commercial
- Industrial
- Non-profit institutions
- State and local government
 - School districts, municipalities, higher education, etc.

q **Separate federal program will be launched soon**

q **Residential programs are separate**

Program Rollout Process

- q **Programs available to all commercial and industrial customers of Met-Ed, Penelec and Penn Power upon launch**

- q **Staged targeted marketing efforts**
 - **First quarter of 2010 – Met-Ed region**
 - **Second quarter of 2010 – Johnstown/Altoona region**
 - **Summer of 2010 – Erie region**

 - **All FirstEnergy customers may participate at any time**

Commercial and Industrial Incentive Programs and Launch Schedule

Program Name	Estimated Launch
C&I Equipment	
Standard/prescriptive Lighting Incentives for Business Non- Standard Custom Incentives	<i>NOW</i>
Standard/prescriptive HVAC Incentives for Business	1st Qtr 2010 Final
Motors & Variable Speed Drives	
Standard/prescriptive Motors/Drives Incentives for Business	1st Qtr

Incentive Programs and Launch Schedule

Program Name	Estimated Launch
Audits/Tech Assistance	
Large Technical Assistance <i>for large end users.</i>	1st Qtr 2010
RFQ process <i>to locate qualified energy audit companies</i>	1st Qtr 2010
Public Sector Program	
Free Audit -Public	1st Qtr 2010
Incentives/Rebates <i>starting now</i>	1st Qtr 2010
Traffic lights conversion to LED lamps	1st Qtr 2010
Street light conversions	1st Qtr 2010
Performance contracting	4th Qtr 2010

Program Forms

Standard form for projects that do not deviate from the form requirements.

Non-standard for projects that do not fit the requirements of the standard form.

All are available at:

www.energysavePA.com



FirstEnergy[®]

Met-Ed • Penelec • Penn Power

Your First Source for Energy Savings

Standard Lighting for Business Program

FirstEnergy's Standard Lighting for Business Program offers incentives and information to encourage non-residential customers to install high efficiency lighting equipment. Funding for this program is paid for by the electric utility ratepayers in Pennsylvania in accordance with Pennsylvania Act 129.



Effective Dates
The specific offerings and incentive levels shown on this form are valid from December 15, 2009 through January 31, 2010, subject to available funds. The Standard Lighting for Business Program will continue beyond January 31, 2010; however, incentives may be added, discontinued, or revised.

Eligible Participants
The Standard Lighting for Business Program is available to all nonresidential electric customers of FirstEnergy in Pennsylvania. This includes customers of MetEd, PennPower and PennElec. utilities. Energy-efficient lighting projects are eligible for these incentives if the equipment was purchased on or after October 28, 2009.

Residential customers are eligible for separate FirstEnergy programs. Please visit www.firstenergycorp.com for more information.

Pre-Approval Requirements
In most cases, program approval is required prior to the purchase and installation of equipment (pre-approval). Because applications will be processed on a first-come, first-serve basis, pre-approval is strongly recommended for all applications to ensure that funding is still available and that the equipment qualifies for an incentive.

Program pre-approval is not required for projects:

- installed before December 15, 2009, or
- applications requesting less than \$3,000 in total incentives.

At any time, customers may contact program staff to discuss a project, get assistance in preparing an application, or with any program-related questions.

Contact a FirstEnergy Business Program representative today at 1-800-XXX-XXXX or visit us online at www.energysavePA.com to learn more.

How Do I Apply for Incentives?

Please review the Business Program Terms & Conditions and application requirements.

Step 1: Complete the program application and attach a copy of supporting technical documentation to verify that installed equipment meets program efficiency levels, such as manufacturers' cut sheets. Submit these materials to the program for pre-approval:

Via mail: FirstEnergy Standard Lighting for Business Program
XXX Some Street, Box XXX
Reading, PA XXXXX

Or Fax: XXX-XXX-XXXX
Or email: energysavePA@saic.com

Incomplete applications will not be considered and will be returned to the applicant for completion.

Step 2: The program will notify the applicant via email when the review is complete and funds have been reserved. Upon receipt of program pre-approval, participants may purchase and install their energy efficient equipment.

Step 3: Update the program application, as necessary, to reflect any changes to the project scope that occurred during installation. Then return the final application to the program, along with a copy of all required supporting documentation, which includes:

- manufacturers' specification (cut) sheets to verify that installed equipment meets program efficiency levels
- dated proof of purchase listing the installed fixtures' make, model, and quantity
- copy of a recent utility bill for the facility showing a MetEd, PennPower or PennElec account number

Applications and supporting technical documentation will be reviewed by program staff, and an onsite inspection to verify the installation may be conducted. Upon receipt and verification of all required documentation, the incentive check will be processed and mailed to the applicant or to an authorized representative, if requested on the application.

If the total incentive requested is LESS THAN \$3,000...pre-approval of the equipment by the program is recommended, but not required. Participants may simply complete the Application Form, attach an itemized invoice or sales receipt dated on or after October 28, 2009 and supporting technical documentation and return to the program for processing. Applications may be mailed, faxed or emailed to the program. Application submission information is listed in Step 1 above.

For more detailed information, please visit www.energysavePA.com and review our Participant's Manual, or contact us at 1-800-XXX-XXXX.

Lighting Program Initial Announcement

q **Programs are under construction**

q **Website – www.energysavePA.com**



q **Applications**

Initial offer - Commercial/industrial lighting projects
where equipment was purchased on or after October 28, 2009

Thru lighting forms through March 31, 2010.



Requirements of Initial Lighting Programs

- q **Purchases and Installations from October 28, 2009 to March 31, 2010**

 - Cut sheets for equipment (manufacturer's specifications)

 - Ballast, factor-efficacy-lamp type and wattages

 - Limit of \$13,000 per standard lighting form

- q **No preapproval.**

- q **After March 31, pre-approval required for projects above \$3,000.**

Non-Standard/Custom Alternatives

- ❑ **Custom Path – Projects use performance efficiencies to qualify for incentives-based on calculations**

Must save energy

- All documentation must be reviewed and pre-approved prior to completion
- Ideal for projects with larger square footage and with multiple ECMs (energy conservation measures) involved.

- ❑ **Energy audit services will be offered to C/I customers:**

- More comprehensive assessment for medium to large with complex loads and customer energy end-uses
- Business cost shared 50/50 with FirstEnergy
- Audits in public program at no cost to applicant

Why is Pre-Approval?

- q **Pre-approval protects the customer and ensures that measures are eligible**
- q **Pre-installation approval -- must submit your documentation to First Energy/SAIC**
- q **Required for all projects over \$3,000 in incentives**
- q **Required for all projects that are considered outside of the established program parameters**

Pre-Approval Requirements

- q **Pre-approval **NOT REQUIRED** for measures purchased/installed between October 28, 2009 and March 31, 2010 (initial offering only)**
 - Incentives based on **incentive schedule in effect on date received**
 - Supplemental worksheet forms required for multiple building projects or incentives greater than \$3,000

- q **Pre-approval required for all incentives greater than \$3,000 after March 31, 2010**
 - Submit documentation for pre-approval (application/cut sheets)
 - Program representatives review and approve documentation for eligibility
 - Customer will receive a letter of pre-approval
 - Applicant may then purchase eligible equipment for installation
 - Applicant submits final “as-built” application form and invoices showing proof of purchase to receive rebates after project completion

Standard vs. Non-standard

Item	Standard	Non Standard
Application Detail	Forms on the Web for program specifications.	Forms on the Web. Calculations analysis basis.
Incentive Amount Potential	Based on average case energy usage	Calculations lead to greater savings typically
Calculation Requirements	None	Savings calculations by consultant/ally
Hours of Use	Average operating hours	Extended operating hours may lead to greater savings
Project Size	Smaller projects	Larger projects
Pre-Approval	Required above \$3K incentive	Scope requires
Proof of Purchase	Required along with cut sheets	Required along with cut sheets

Technologies and Incentive Levels

- Using the standard approach, there are a variety of prescriptive equipment that qualifies for incentives dictated by Act 129.



Sample Building *Potential of multiple opportunities - Could be standard and non-standard.*





Variable Frequency Drives



MOTORS



HVAC



LIGHTING

- FACILITY ENERGY AUDITS
- TECHNICAL ASSISTANCE

High Efficiency Motors

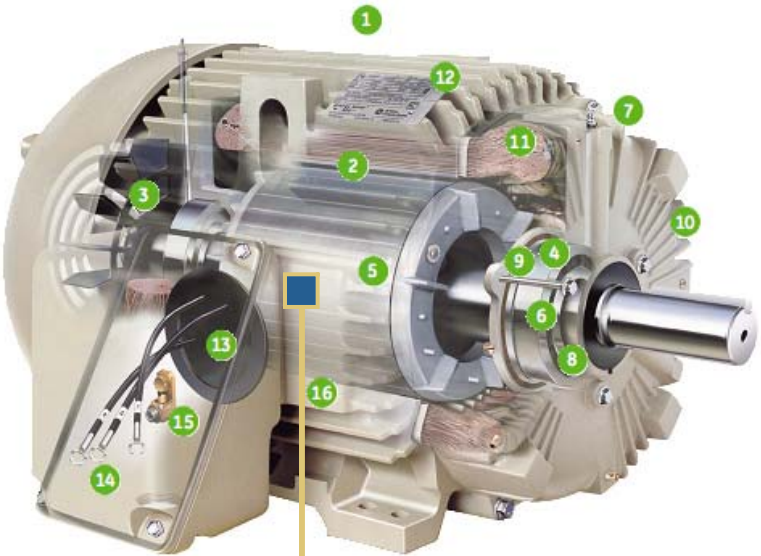
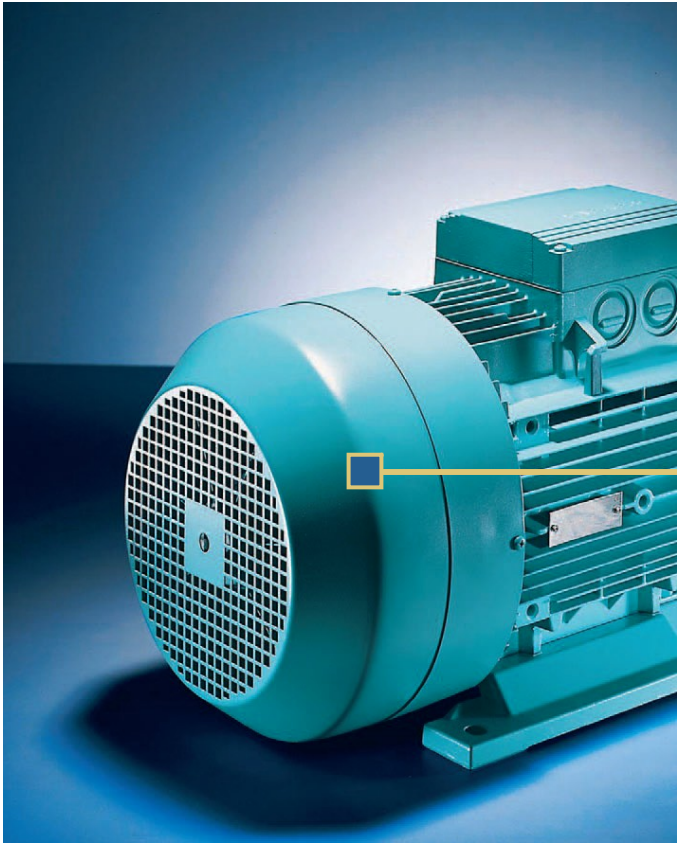

PA - Residential Programs

1. **Appliance Turn-In Program**
2. **Home Energy Audits (on-line and walk through)**
3. **Residential Incentives for HVAC**
4. **Energy-Efficient Products Program – incentives range from \$1 for a CFL to \$500 for a solar water heater**
5. **New Construction Program – developed 2nd quarter 2010**
6. **Whole Building – comprehensive on-site audit**
7. **Multi-Family Tenants – Tenants in buildings covered under PHFA program may participate in lighting retrofits**
8. **Low-Income - additional electric savings measures to existing WARM program**

Where to go for more information

Program Representatives

SAIC Program Representatives

Rick Diioia	Deputy Program Mgr	610-594-4301
Linda Rasor	Sr. Outreach Lead	484-252-9101
Danny Small	Eastern PA Program Representative	610-594-4301
Ray Pacunik	Western PA Program Representative	814-241-3123

Visit the Web often for new program releases
at www.energysavePA.com

Thank You